



# The Revenge KR842VHD Amplifier

Don't tell this author tube technology is passé. Using a latest-generation tube from Czechoslovakia, he's put together a high-performance SE amp. **By Mauri Pännäri**

**T**his basic high/medium power SE amp uses the best-quality components available on the market, such as the new KR842VHD high dynamic power triodes and Lundahl C-core transformers. I put special effort into choosing the driver tube: the old telephony workhorse C3m in triode mode and capacitor-coupled. The pre-driver 12BH7 is a proven low-gain component for good and detailed sound, too. Simple, although not very cheap, the result is a quiet, dynamic unit, sonically different from the usual 300B designs.

## INTRODUCTION

Hi-fi (and lately, tube hi-fi) has been my hobby for about 35 years. There have been many things to see—from some clever innovations to circuit and theory nonsense. I thought, as many others probably have, that the tube times were totally over and the development ceased until the '80s, when I found Jean Hiraga's book of Japanese tube trends in my hand.

At that time I was partly involved in tube technology at Telecom Finland (now Sonera Corporation). I headed the repair work of professional speech transmission measuring equipment, older oscilloscopes, and other tubed

**PHOTO 1:**  
The completed amp.

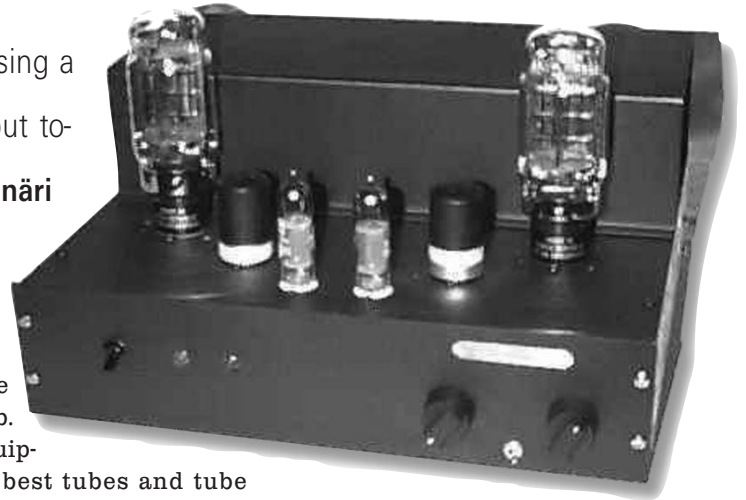

test gear in the repair center lab. This kind of equipment used the best tubes and tube types available on the market, without consideration of cost.

Many used samples were available, so I began to experiment with some promising circuits and came to the well-known single-ended push-pull (SEPP) bridge design, which was invented here in Finland in the mid-50s by a legendary national radio and hi-fi guru, Tapio M. Köykkä (1911-1994). SEPP can be traced to his two patents from that time, which were immediately copied in the US and Germany by Electro-Voice and Philips. This background is not commonly known, and the origin of the concept is most often attributed to Electro-Voice. This circuit is the mother of current OTL tube designs of a particular category.

My then new SEPP 4W 6BX7 triode construction was such an excellent performer that I had to sell my Yamaha 1010 top receiver right away. I thereafter played happily for many years with my SEPP (it's still in full service at my summer house). However, around that time I happened to have some 4300A carrier-wave transmission telecommunications tubes made by Standard Telephones and Cables (STC) in England, and was inspired at last to try a single-ended design with these old direct-heated triodes, which are very scarce today. This is actually the same tube as the 300B

with identical electrical STC data to the STC 4300B.

I also saved some STC 4328A drivers from work. This is like the WE 310A but with a 7.5V heater. Both of these STC types were unused spare parts for telephone 12-channel open-wire carrier-wave telephony transmission amplifiers from the '50s. The 4300A was the open-wire line transformer power feeder (I have a plan to build a STC-tubed replica of the WE 91B amp in the future).

## TUBE SELECTION

Over four years ago I selected my own SE driver tube for a 300B-type DHT by listening to a variety of tube types and manufacturers in my capacitor-coupled circuit, as samples were easy for me to get. At last I decided: Siemens C3m in triode mode with excellent sound and good swing capability. This long-life steel pentode was common in the '50s and '60s as a channel amplifier in German speech carrier-wave telecommunications equipment and also in measuring equipment, despite its expense. The market price now is upwards of \$50, available from major dealers. The steel-shield construction holds a glass envelope within and has a mesh anode structure.

I ordered my Tango U-808 output transformers from Japan, because there

## ABOUT THE AUTHOR

Mauri Pännäri (M.Sc. e.e.) has worked 30 years in professional telecommunications repair, construction, measurement, planning, and research at Telecom Finland (now Sonera Corporation). Hi-fi has been his hobby from the age of 15, when he built his first tubed amp with 2x EL84s. He enjoys classical music, as well as rock and roll, as played through his vintage 300 ltr 15" Tannoy Monitor Golds. He mainly spends his free time with his family at a well-stocked inland lake in the southern part of Finland.

were none available in Finland at the time. I have been happy with my 300-type SE for years, although I've tried various other circuits beneath.

During the 1999 Hi-fi Fair in Finland I happened to meet Dr. Riccardo Kron and his wife, founders and owners of KR Enterprise, which was offering some of its top Czech amplifier models in Finland. We discussed at length DH tubes, vacuum transducers (the high power tube component from KR), and using them in constructions. After that, my wife and I visited the Krons in Prague, seeing and hearing much about DH tube manufacturing in the old Tesla tube lab premises they now own.

In addition to the existing models, we listened to a new tube, the KR842VHD, which was just in the release phase in the factory, and is now used in one of KR Enterprise's top amp models. It is also available to constructors worldwide via dealers (also here in Finland) as a next-generation 300B replacement or a basis for something better. I was very impressed by its sonic potential.

I decided to build a totally new SE construction, which I present here (*Photo 1*). I was, however, curious and plugged my new 842 tubes into my old 4300 design. After trimming the DC heater voltage for bigger current, they flashed their sonic potential with 300V/70mA supply only.

The dynamics I heard again caused me difficulty in choosing output transformers of comparable quality for the new construction. I decided to purchase the whole iron set from Lundahl (Sweden), as I noted some good references in various articles and on the net, and the prices were reasonable. Mr. Lundahl was also very helpful and the delivery was quick.

## DESIGN

The KR842VHD output tubes work here (*Fig. 1*) with 420V/95mA with a fixed bias of about -62V, which is provided with a separate 3VA transformer via 180kΩ resistors to the grids. The rectified 5.9V AC heater voltage is just right and will accommodate other 5V/1A 300-type tubes as well. The tube is loaded with Lundahl's LL 1623, a C-

core multi-winding quality SE iron.

My version is specified to 90mA max, but can be used, according to Mr. Lundahl, for even 105mA flux with essentially higher main inductance than the following standard version with a bigger air gap for 120mA. Its numerous secondaries are coupled for 3kΩ anode load with a printed circuit board, "PCB\_C," available from the manufacturer (this can be done by wiring also). There is nearly 2dB local feedback by connecting the output secondary to the cathode. This is a trick that non-feedback purists

can use with positive properties and was long ago used even with a 1:1 ratio in some commercial push-pull designs, such as Quad, MacIntosh, and Finnish Köykkä. It increases the DC magnetization flux of the output transformer by about 5%, which is marginal.

I have had very good results with high-mu tubes in my other SE trials. If you have mu around 20, you can have 5-7dB of feedback and a very fixed bass end from a modest power SE. Here the practical influence is quite small with the tube-mu around 4. This tube has the



## Chelmer Valve Company Ltd.

The Stables, Baddow Park, Great Baddow, Chelmsford  
Essex, CM2 7SY, England.

email: sales@chelmervalue.com \*\* tel. 44 1245 241 300 fax. 44 1245 241 309 \*\* www.chelmervalue.com

### for High Quality Audio Tubes

Everybody in the audio tube business knows that the justly famous brand names of yesteryear like Brimar, GEC, Mullard, RCA, Telefunken etc. etc. are scarce and often quite expensive. Although we supply all major brands as available (and we have many in stock) our policy is to offer a range of tubes, all new and mostly of current manufacture, the best we can find from factories around the world, which we process to suit audio applications. The result - CVC PREMIUM Brand. Our special processing includes selection for **low noise, hum & microphony** on pre-amp tubes and controlled **burn-in** on power tubes to improve **stability** avoid tubes with weaknesses etc.

#### \*\*\*\*\* A selection of CVC PREMIUM Audio Tubes \*\*\*\*\*

| PRE-AMP TUBES       | POWER TUBES           | POWER TUBES cont.   | RECTIFIERS cont.         |
|---------------------|-----------------------|---------------------|--------------------------|
| ECC81 5.90          | EL34G 8.30            | 6L6WGC/5881 8.90    | 5Y3GT 4.80               |
| ECC82 5.90          | EL34 (JJ) 8.50        | 6V6GT 5.50          | 5Z4GT 5.80               |
| ECC83 5.90          | EL34(Large Dia) 11.00 | 6080 11.50          | <b>SOCKETS ETC.</b>      |
| ECC85 6.60          | EL84 5.50             | 6146B 11.00         | B9A (Ch or PCB) 0.60     |
| ECC88 5.70          | EL509/519 13.00       | 6336A 48.00         | Ditto, Gold Pl. 3.00     |
| ECF82 5.50          | E84L/7189 7.50        | 6550WA/WB 15.00     | Octal (Ch or PCB) 1.80   |
| ECL82 6.00          | KT66 11.00            | 7581A 12.00         | Ditto, Gold Pl. 4.20     |
| ECL86 6.30          | KT66R 22.50           | 807 10.70           | UX4 (4-Pin) 3.60         |
| EF86 6.00           | KT77 13.20            | 811A 11.80          | Ditto, Gold Pl. 5.50     |
| E80F Gold Pin 11.00 | KT88 13.50            | 812A 31.00          | 4 Pin Jumbo 10.00        |
| E81CC Gold 8.00     | KT88 (Special) 17.00  | 845 (New des) 33.50 | Ditto, Gold Pl. 13.00    |
| E82CC Gold 9.00     | KT88 (GL Type) 30.00  | <b>RECTIFIERS</b>   | 5 Pin (For 807) 3.30     |
| E83CC Gold 8.50     | PL509/519 9.90        | EZ80 5.10           | 7 Pin (For 6C33C) 4.70   |
| E88CC Gold 8.80     | 2A3 (4 pin) 15.50     | EZ81 6.00           | 9 Pin (For EL509) 5.00   |
| 6EU7 7.00           | 2A3 (8 Pin) 17.50     | GZ32 15.50          | Screen can B9A 2.20      |
| 6SL7GT 8.90         | 211 23.00             | GZ33 15.50          | Ditto, Gold Pl. 4.30     |
| 6SN7GT 5.30         | 300B 45.00            | GZ34 7.20           | Top Con. (For 807) 1.70  |
| 6922 6.40           | 6C33C-B 25.00         | GZ37 15.50          | Ditto, (For EL509) 2.00  |
| 7025 7.00           | 6L6GC 7.60            | 5U4G 6.30           | Retainer (For 5881) 2.20 |
|                     | 6L6WGC/5881 8.90      | 5V4GT 5.00          |                          |

#### \*\*\*\*\* And a few 'Other Brands', inc. rare types \*\*\*\*\*

|                      |                      |                     |                      |
|----------------------|----------------------|---------------------|----------------------|
| 5R4GY Fivre/GE 8.50  | 6SL7GT STC 13.00     | 13E1 STC 100.00     | 6550C Svetlana 18.00 |
| 5R4WGY Chatham 10.50 | 6SN7GT Brimar 13.00  | 211/NT4C GE 120.00  | 6146B GE 18.50       |
| 5Y3WGT Sylv. 6.50    | 12A77WA Mullard 6.00 | 300B JJ 56.00       | A2900 GEC 15.00      |
| 6AS7GT Sylv. 12.00   | 12AU7 Mullard 12.50  | 300B Svetlana 80.00 | E88CC Mullard 14.60  |
| 6AU6WC Sylv. 5.10    | 12AY7 GE / RCA 8.40  | 300B WE 195.00      | F2a Siemens 145.00   |
| 6B4G Sylv. 27.00     | 12AZ7 West 'h. 8.00  | 805 USA 52.00       | KT66 GEC 69.00       |
| 6BW6 Brimar 5.40     | 12BH7A RCA 14.00     | 5842A GEC 15.00     | KT88 JJ 17.40        |
| 6BX7GT GE / RCA 9.00 | 12BY7A GE 9.50       | 6080 Telef. 13.30   | KT88 Svetlana 35.00  |
| 6CG7/6FQ7 8.50       | 12E1 STC 12.50       | 6550A GE 31.50      | PX25 KR 128.00       |

#### ALL PRICES IN U. K. POUNDS £

Please note extras: carriage charge (£3.00 in U.K.) & in EEC VAT (17.50%). When ordering please state if matching required (add £1.00 per tube) . Payment by credit card (VISA, AMEX etc.) or TRANSFER or CHEQUE (UK only).

FAX email or POST your ORDER for immediate attention - We will send PROFORMA INVOICE if required.  
MILLIONS OF OTHER TUBES & SEMICONDUCTORS IN STOCK!

**\*\* Valve Amplifiers sound better still with CVC PREMIUM Valves! \*\***  
**PRICE VALIDITY TO END APRIL 2002 - ASK ABOUT ANY TYPES NOT ON THIS LIST**

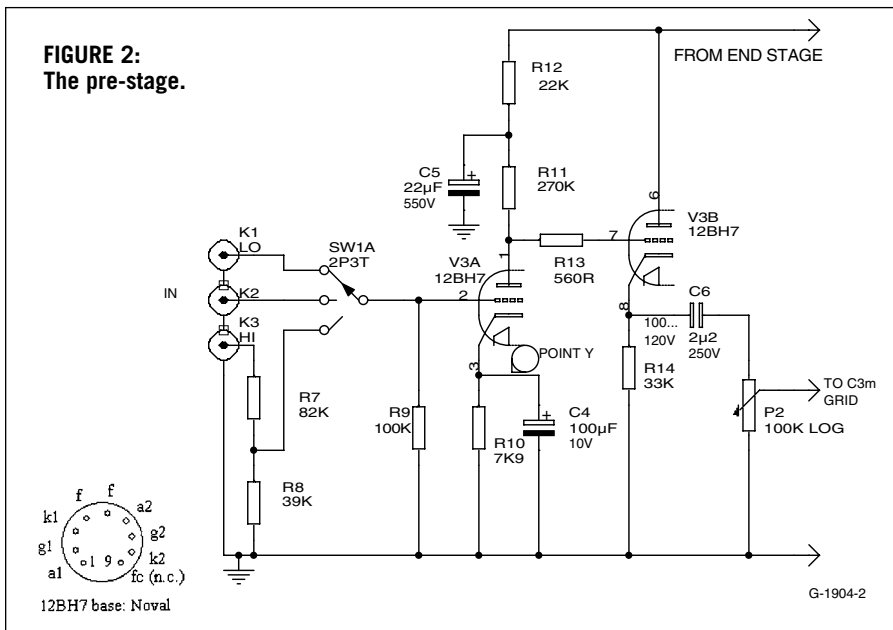
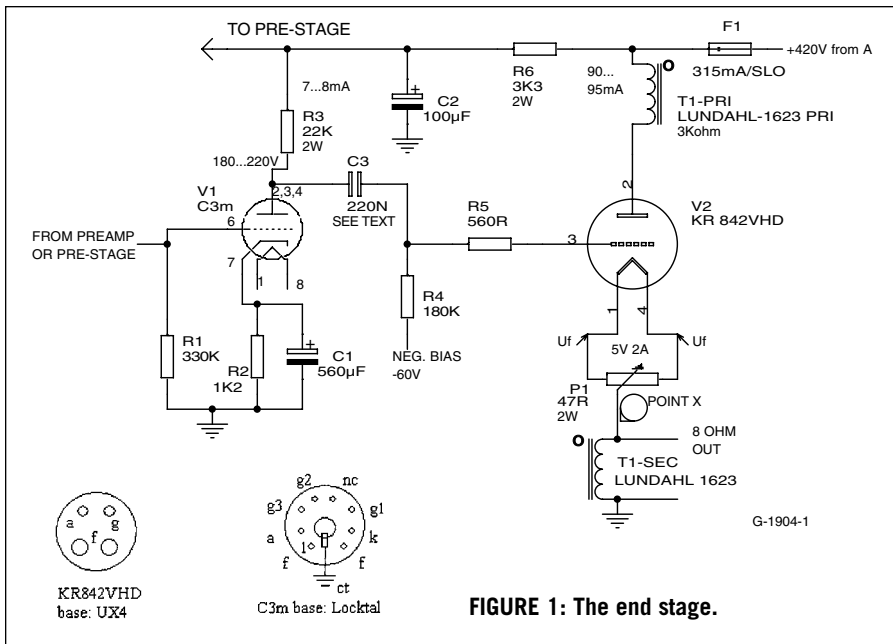

same base configuration as 300B-types with the UX4 base, although the inner construction is totally different with eight separate flat cathodes.

### CIRCUIT OPERATION

The signal coupling capacitor is of great importance. I used proven Wima FKP1, 0.22µ/1250V foil polypropylenes (“blue” series), which were readily available. You can use your favorite audio special capacitors here, maybe spending several tens of dollars, if you consider it worth it.

I saw no reason to change my good driver tube and concept, after the preliminary short successful trial with the

842s to check the combination sound. This stage with C3m as triode is conventional with an anode load of about ten times  $R_i$  and reasonable current, to feed the output tube, which here works in pure Class-A1, meaning you don’t go to the grid current drive region on purpose. Actually, the driver I use here is C3o, which is the 6.3V version of C3m, but these are extremely rare and you might better use C3m by adding a 2× 3V/3VA aid transformer, separated 3V halves in series with the main transformer’s series coupled 6.6V windings to get near 20V AC (note and turn the 3V phases if necessary).

The stage has a gain of 15 and good

linearity, so sensitivity around 3V RMS is obtained at the grid for over 45 RMS volts out for the output tube. This tube needs a special base called a “locktal.” For triode mode, just connect electrodes a, g2, and g3 straight together (pins 2, 3, and 4). If you have a suitable good preamp with enough output capability, you can build these two stages per channel as a mono or stereo end block, as was my earlier mentioned 300-type design. An extra pre-stage is still needed if you want to have a complete amplifier with line level inputs, as I decided to include here.

The pre-driver stage (Fig. 2) does not need much gain. I have tried SRPP with a wide variety of tube types in the past, as well as semiconductor constant-current loading, and decided here to keep on the basic gain stage with a big value anode resistor using a sonically well-proven tube. So I turned again to a favorite of mine—the Philips 12BH7. With low current of 1mA from 350V and an anode load of over 40 times  $R_i$ , the first stage fits straight and practically as unloaded, to a 3–4mA cathode follower using the other triode in the same tube. You will have some 100–130V DC at the cathode as a guide value.

The first stage gain is about 12, offering a final sensitivity of 300mV. I provided one input with 10dB lower sensitivity (and a little bit lower input impedance) for high output sources (e.g., a CD player without a volume control), because it is against my design principles to put the volume control before the whole tube gain chain and have all the front-end noise and possible residual hum present at the output all the time. So the 100kΩ volume potentiometer lies behind the cathode follower coupled with a big polypropylene (Wima “red” MKP used here), a proven solution and good compromise (you would have the capacitor in a separate tube preamp in most cases, anyway). This allows me also to parallel-record to my old reel tape (the rec. connectors wired from the top of the volume control are not shown in the schematic).

You have only a few volts signal normally at the cathode output related to the space of several tens of volts available, with respectively small distortion. If you choose, you can put a cermet pre-

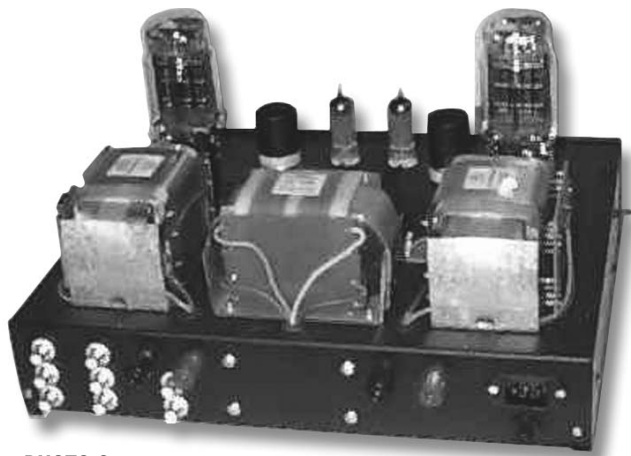

**PHOTO 2:**  
With top cover removed.

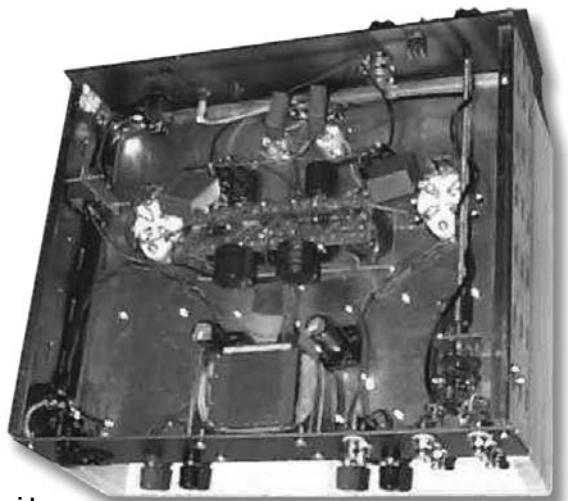

**PHOTO 3:** Amp underside.

set/balance potentiometer in place of the voltage divider to adjust the input to the maximum level used frequently.

There is not much more to say about the basic circuit. It is elementary and proven with no tricks. Sound relies on top-quality components and tubes and their sonically proven match.

### CONSTRUCTION

I constructed the amplifier around an old 19" rack case, which I narrowed and

shortened, and used a new cover/back of 1.5mm aluminum as the mounting template, painted black. You can use any suitable case (such as a Hammond), or make your own. The Lundahl transformers are no Miss World beauties (*Photo 2*), so I constructed an aluminum cover for them as shown in *Photo 1*.

The Lundahl LL1638 choke is under the chassis. All irons have 90° physical axis relation, more as a good design factor for these low leakage C-core irons.

The input selection switch is located near the inputs in the back corner behind a rotation bar, so no screened wires are needed there (*Photo 3*). You could also consider using small relays for this purpose, activated by a front panel switch.

The power supply is conventional (*Fig. 3*). Separate 5.9V windings from the universal (115/230V) Lundahl LL1648 mains transformer feed the output tube heater rectifiers. I finally re-



*CT2 6-gang  
volume control for A/V Audio*

#### General attenuator specifications

|                       |        |        |
|-----------------------|--------|--------|
| Number of steps:      | 24     |        |
| Bandwidth (10kOhm):   | 50     | MHz    |
| THD:                  | 0.0001 | %      |
| Attenuation accuracy: | ±0.05  | dB     |
| Channel matching:     | ±0.05  | dB     |
| Mechanical life, min. | 25,000 | cycles |

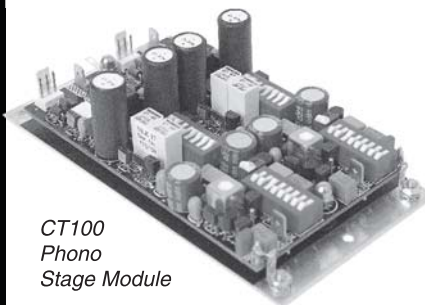

*CT100  
Phono  
Stage Module*

#### CT100 key specifications

|                           |            |     |
|---------------------------|------------|-----|
| Gain (selectable):        | 40 to 80   | dB  |
| RIAA eq. deviation:       | ± 0.05     | dB  |
| S/N ratio (40/80dB gain): | 98/71      | dB  |
| THD:                      | 0.0003     | %   |
| Output resistance:        | 0.1        | ohm |
| Channel separation:       | 120        | dB  |
| Bandwidth:                | 2          | MHz |
| PCB dimensions:           | 105 x 63   | mm  |
|                           | 4.17 x 2.5 | "   |

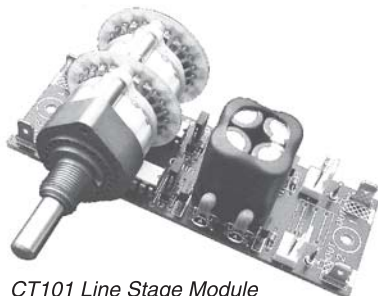

*CT101 Line Stage Module  
with a stereo CT1 attenuator added.*

#### CT101 key specifications

|                         |             |      |
|-------------------------|-------------|------|
| Gain (selectable)       | 0, 6 or 12  | dB   |
| Bandwidth (at 0dB gain) | 25          | MHz  |
| Slew rate (at 0dB gain) | 500         | V/uS |
| S/N ratio (IHF A)       | 112         | dB   |
| THD                     | 0.0002      | %    |
| Output resistance       | 0.1         | ohm  |
| Channel matching        | ± 0.05      | dB   |
| PCB dimensions:         | 100 x 34    | mm   |
|                         | 3.97 x 1.35 | "    |

**DACT**  
DANISH AUDIO CONNECT  
**DACT**

Sales Dep.: Tel.: (+66) 2 260 6070  
Fax: (+66) 2 260 6071  
E-mail: info@DACT.com

<http://www.DACT.com>

**High quality audio parts** for upgrading existing equipment, DIY constructions and for audio equipment manufacturers. DACT audio components offer unusually large bandwidth, low distortion, high accuracy, low noise and long lifetime. DACT products:

- Stepped Audio Attenuators
- Stepped Balance Controls
- Audio Input Selector Switches
- Phono Stage Module
- Line Stage Module
- Different Accessories

**Made in Denmark**

placed the 47Ω potentiometer (P1) with two 33Ω/2W fixed resistors, but you can install these at the outset. The other two 6.6V heaters are in series—the center earthed—to feed 13.2V for the driver and front end tubes.

You need a small 2× 3V/3VA aid transformer to provide 3V extra to both ends of the center earthed 13.2V for the C3ms, reaching over 19V total; 19–21V is acceptable here. The grid bias is provided by a separate 30V/3VA transformer, and mine gives around –60V DC with no load. This depends on the mains voltage and the transformer and may need some trimming.

Typically these small PC-board transformers provide about 35% overvoltage with no load as used here. They can be conveniently fixed by a strip of PC board with holes at the ends and two 40mm-long bolts upside down against the case, wires welded directly to the pins. Both the small transformer primaries are behind the fuse F1—although not drawn in the schematic—from where I also dropped the mains switch and pilot light.

You can cut at the point X in the output amplifier schematic (Fig. 1) to add a 10–50Ω/1W aid resistor in series to lift the negative bias voltage if needed, roughly with –1V/10Ω add. It may be a good idea to put some 100Ω here in the initial phase and then come down to reach the anode current value in the region of 90–100mA. I finally left 33Ω for 95mA, not wanting to change to a new 36V AC secondary bias transformer. This can also be done, but needs a voltage splitter/potentiometer for adjusting for the bias needed.

The aid resistor also has a bonus of stabilizing the current to some degree, and I noticed no sonic or measurable side effects as left unshunted. The semiconductor-rectified anode supply uses 400V capacitors for switched-mode power supplies in series with paralleled voltage dividers, forming a pi-filter with the choke. The driver and the pre-stage have additional RC-filtering. Purists can use tube rectification here with possible choke input, selecting a different mains transformer accordingly and getting a delayed anode voltage as a bonus.

A trick I've recently seen is to use

two semiconductor diodes and two tubes or a double tube in a Graetz bridge arrangement with all the good and bad properties of tube rectifiers. You need only one anode voltage winding then. GZ34 could be good, or you could use two color TV boosters, e.g., EY500s. The anode voltage will be about 30–40V lower. I have not tested them in this amplifier. You could also try hexfreds.

I have switched mains on to my old 4300s (without any anode delay or heater softening) several times daily for nearly five years with exactly the same kind of power supply for 300V as here. It has been useless to research information about the meaning of delayed anode voltage instead of the “would be good or necessary” nonsense frequently offered, and this gives me the impression the subject is not very meaningful in our 80-year tube time frame. The same holds for soft heater start-up. I seldom saw them in professional equipment where selenium or diode rectification provided immediate full anode voltage to “shock heated” tubes, when heading the centralized repair work of tubed telephony and measuring equipment in the beginning of my career.

### OPTIONS

Those who choose to, and have skills to experiment, can try some changes of interest. If it is impossible to get C3m tubes, you could try ECC81 or its corresponding telephony type 33A/101K, which was sonically the second best driver for my tastes for my earlier 4300 design. It has a gain of about 40 here and needs different load and biasing. You can try 30–40k at the anodes with 5mA. You can also parallel-couple the halves.

With this tube there is sensitivity without a pre-stage for a CD player. However, I recommend you keep on the C3m for best sonic results. You can, if you prefer, use an SRPP pre-driver built around the two front-end tubes; it was my original idea to install two double tubes here for stereo to maintain flexibility to easily work with various front ends. Cathode-follower

haters can leave one tube or parallel-couple the tube halves for a normal gain stage in each channel.

E182CC (7119) is a good, proven tube candidate for the front end, too. Still, you could try semiconductor current generators as anode loads (e.g., “Camille cascodes,” which withstand, however, only about 300V). I have prototyped this end amp with an E182CC having 3mA constant-current semiconductor loads from 120V in the test phase, and the result was fine, although maybe with a more “sterile” sound influence. There are a lot of options available, which I leave to you.

After having tried various tricks and possibilities during my years of experi-

**TABLE 1**  
**THE REVENGE KR842VHD**  
**AMPLIFIER PARTS LIST**  
**(PER ONE CHANNEL,**  
**ALL RESISTORS ½W**  
**UNLESS OTHERWISE NOTED)**

#### END AMPLIFIER

|    |   |
|----|---|
| R1 | 330k  |
| R2 | 1k2   |
| R3 | 22k/2W  |
| R4 | 180k  |
| R5 | 560R  |
| R6 | 3k3/2W  |
| P1 | 47R/2W wirewound linear potentiometer, see text |
| F1 | Fuse T315mA (slow)                              |
| C1 | 560μF/16V electrolytics                         |
| C2 | 100μF/550V electrolytics                        |
| C3 | 0.22μF/1250V polypropylene Wima FKP, see text   |
| T1 | Lundahl SE transformer LL1623/90mA              |

#### PRE-STAGE

|     |  |
|-----|--|
| R7  | 82k  |
| R8  | 39k  |
| R9  | 100k   |
| R10 | 7k9, see text                                    |
| R11 | 270k   |
| R12 | 22k  |
| R13 | 560R   |
| R14 | 33k/1W   |
| P2  | 100k stereo log pot cermet or other high quality |
| C4  | 100μF/10V electrolytics, tantalum                |
| C5  | 22μF/550V electrolytics                          |
| C6  | 2.2μF/250V polypropylene Wima MKP 10             |
| SW  | 2 × 3 switch, e.g., Elma gold-plated             |

#### POWER SUPPLY

|          |  |
|----------|--|
| T1       | Lundahl universal mains transformer LL1648 |
| L1       | Lundahl 10H anode choke LL 1638            |
| T2       | Transformer 2 × 3V/3VA out, see text       |
| T3       | Transformer 30V/3VA out, see text          |
| B1       | Diode bridge 1000V/4A, see text            |
| B2, B3   | Diode bridge 100V/20A                      |
| B4       | Diode bridge 200V/1A                       |
| C7–C10   | 330μF/400V electrolytics                   |
| C11      | 100μF/100V electrolytics                   |
| C12, C13 | 10mF/16V electrolytics                     |
| R15–R18  | 100k/2W                                    |
| F2       | Fuse T1A (slow)                            |

menting, my ears felt as though they were returning home with my 12BH7 "normal" stage here. For skilled experimenters the field is endless, and there really are nuance differences in sound, the best remaining unfound (luckily). Also, the working point of the voltage gain stage makes a difference.

High-current enthusiasts may increase the first stage current. I have noticed special "nuance switches" in some designs for pre-stage bias. Here, however, you should not lift the cathode follower's DC voltage much over 100V to remain safe with the maximum positive DC + AC under 200V, as specified for the 12BH7 tube as heater grounded! For other tubes, see their data sheets for safe operation in this respect.

There is the point Y in the preamp schematic (Fig. 2). If you cut there you can eliminate the cathode capacitor and experience a little bit different sonic result—at the expense of smaller, but sufficient, gain. My last trial was

with the Philips Miniwatt E80CC, which fits pin-to-pin, but you must change the cathode resistor R10 in each channel from 7.9k to 3.4k to achieve 100–110V at the anode. This tube sounds very relaxed here without the cathode bypass. This is an excellent preamp, even though it was built separately for different purposes.

If you want to use other UX4-socket 5V output-tubes, there is a wide variety to try. The sound is typically different in each case. Remember to adjust the bias for the anode current needed; the heater is sturdy as such for any current at 5V up to about 2.5A DC.

With these good irons and driver tubes, I recommend the new KR842VHD high dynamic tubes for something sonically better than usually heard. If you are not sure what to do, follow the types and values presented here; the result is good. Remember the safety factors!

The bandwidth of the amp is from

10Hz to over 30kHz within 1dB. I don't like to go any further than this.

I had the opportunity to listen to the best KR amplifiers in Prague and also here at a local dealer (Ideale High Fidelity, Finland), and to me they have their recognizable, detailed, and more dynamic sound, different from my traditional 300s. In my opinion, my design has reached the same authoritative level, which fits my purpose. The power, over 13W, is also more than sufficient for my 15" 95dB/W Tannoy Monitor Golds, allowing play within the first and cleanest SE watt in normal listening and also reaching live-like orchestra sound frontiers when necessary. ❖

### COMPONENT SOURCES

www.kr-enterprise.com  
 KR842VHD tubes, including list of dealer sources  
 Billington Export Limited  
 Gilmans Industrie Estate  
 Billingshurst, West Sussex  
 RH14 9EZ, England  
 billingtonexport@btinternet.com  
 (see also advertisements in GA)  
 C3m tubes/bases  
 www.lundahl.se  
 Lundahl transformers, including list of dealer sources

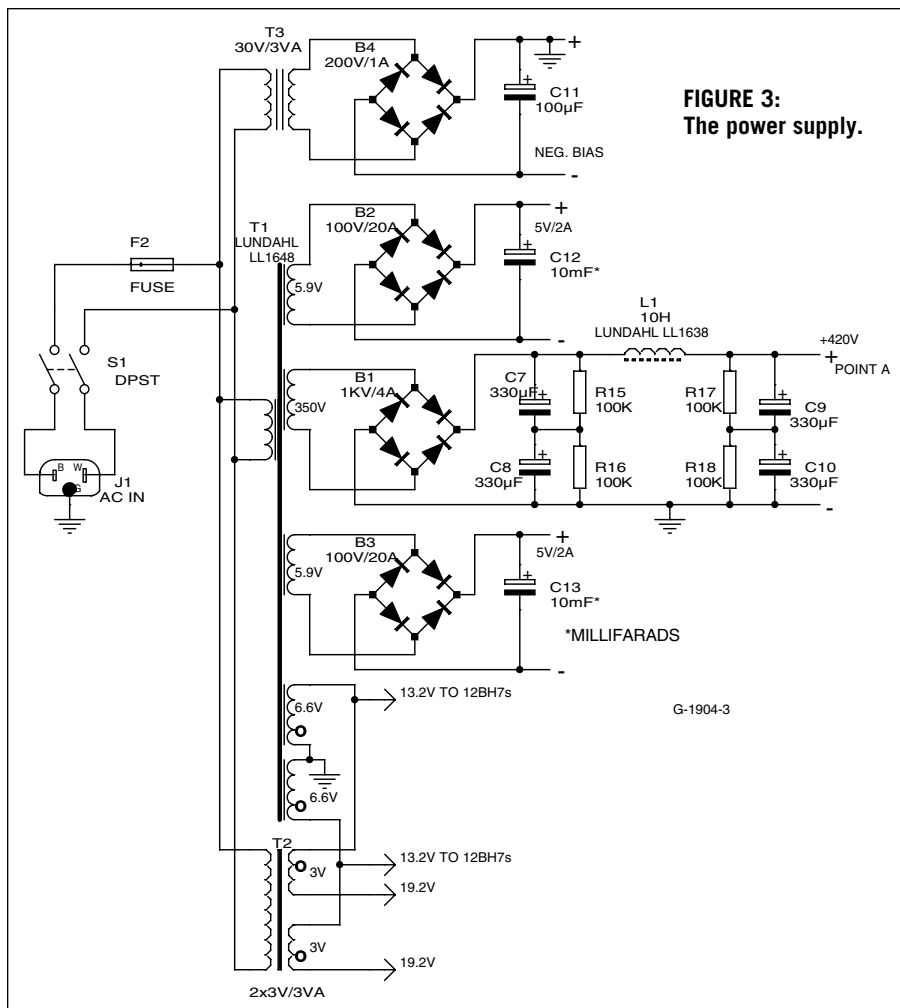

FIGURE 3:  
The power supply.

## CONSONANCE by Opera Audio

High End Tube Equipment at Affordable Prices!



Preamps, Power Amps, Intergrated and Headphone Amplifiers

**NEW!** from Consonance  
 the REFERENCE Line  
 the CYBER (mini component) Line

**NEW!**  
 the PHONOMAX MM/MC Phono Stage

ALSO

- EarMax, EarMax Pro Headphone Amps
- EuroLab Turntables (kit or assembled)
- Golden Gate, Mørch, Schröder Tone Arms
- Allaerts, Denon, Empire, Ortofon Cartridges

(Dealer Inquires Welcome)

**AUDIO ADVANCEMENTS LLC**

973 875 8705 • audadv@earthlink.net

www.audioadvancements.com